

**PRESSURE REDUCING VALVE****EUROBRASS 142 MM**

- Direct acting brass pressure reducing valve;
- PN 25;
- Adjustable outlet;
- Brass diaphragm mechanism;
- Pressure compensation system;
- Male union threading;
- Max temperature of use 80° C;

**FIELDS:**

The pressure reducing valves series EUROBRASS 142 are suitable for reduction and control of pressure in plants with the following characteristics:

Max inlet pressure:	<b>25 bar</b>
Field of action (outlet pressure):	<b>0,5 - 6 bar (1/2" to 2")</b>
Max temperature of use:	<b>80° C</b>
Threading of connection:	<b>ISO 228</b>
Tested according to rules:	<b>DIN EN 1567</b>
Suitable fluids:	<b>Water, compressed air</b>
Reduction rate :	<b>10 : 1</b>

**MATERIALS:**

Metal of the body:	<b>Brass alloy CW617N UNI EN 12165 - CB753S EN 1984</b>
Metal of the inner parts:	<b>Brass alloy CW614N UNI EN 12164</b>
Seat:	<b>Stainless steel AISI 303</b>
Bar:	<b>Brass alloy CW614N UNI EN 12164</b> <b>Stainless steel AISI 303</b>
O-rings:	<b>NBR 70sh</b>
Flat gaskets:	<b>Fasit Italy</b>
Plastic parts:	<b>Ultramid® A3K (BASF)</b>

### MAIN DIMENSIONS OF THE PRESSURE REDUCING VALVES EUROBRASS 142

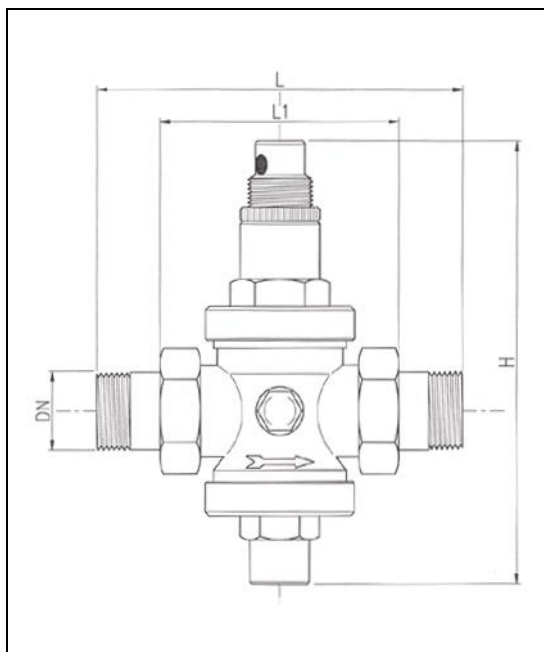

ITEM N	DN	weight gr	H	L	L1
142.12	1/2"	860	120	112	75
142.34	3/4"	950	120	134	88
142.33	1"	1.700	160	140	93
142.114	1" 1/4	2.880	220	185	131
142.112	1" 1/2	3.040	220	190	131
142.58	2"	5.130	250	260	140

### FLOW RATE vs PRESSURE DROP CHART:

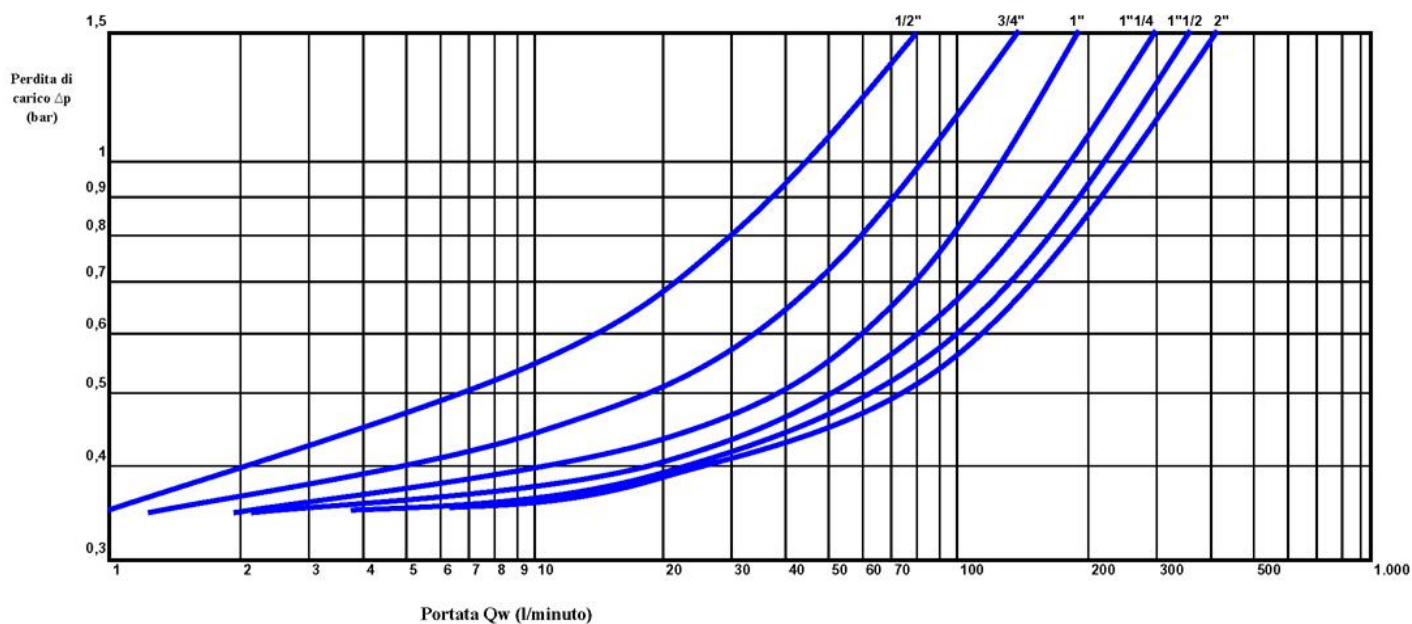

### FLOW vs FLOW CHART:

#### VALVE SIZING CHART PRESSURE REDUCING VALVES EUROBRASS

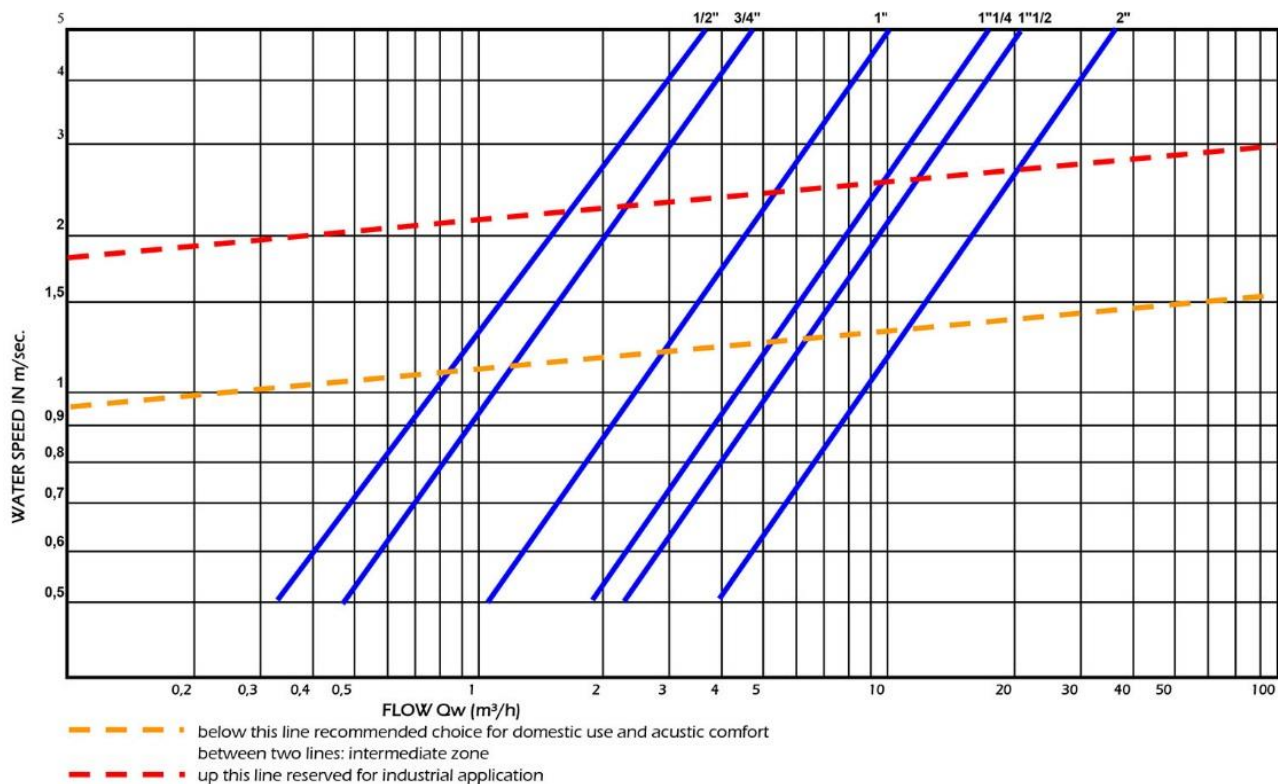

### CAVITATION CHART:

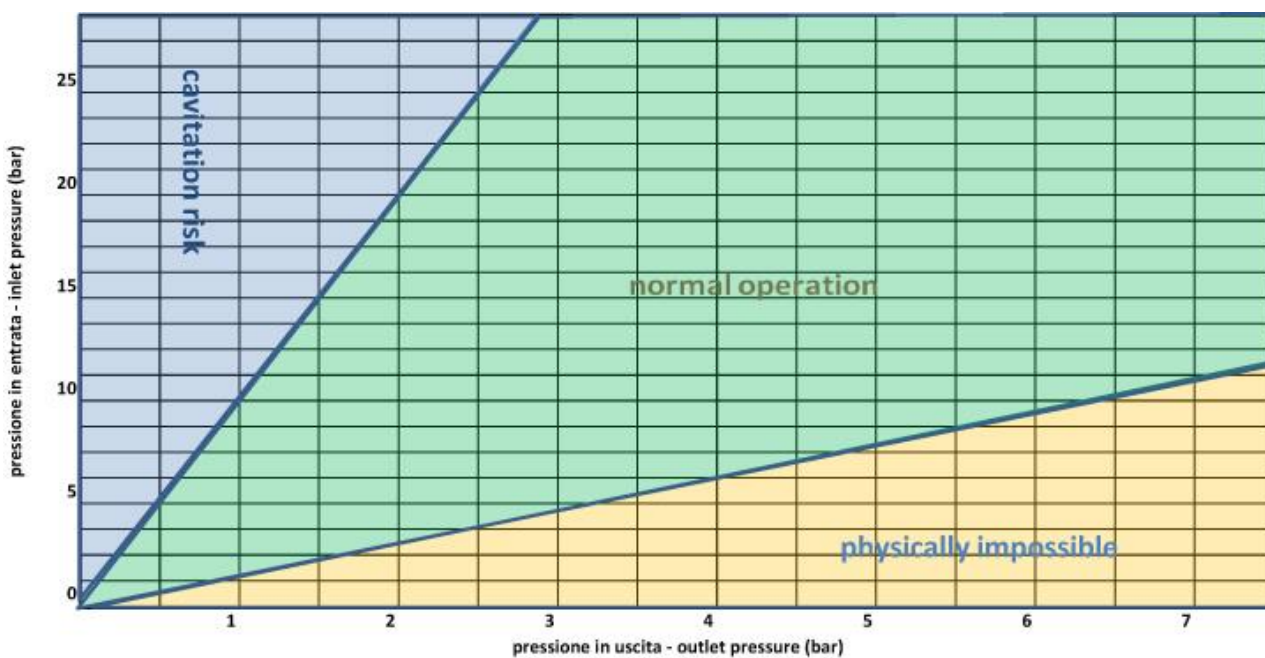

## BEST HYDRAULIC DISCHARGE OF PRESSURE REDUCERS EUROBRASS 142

In order to choose the best pressure reducers for any plant, we suggest to follow the indications mentioned in the underexposed table with the best running pressure of the valves Eurobrass 142.

The values are indicated both in litres/minute and cbm/hour and determine the field of use where you can obtain best functioning, silence and smaller pressure drop.

MODEL	SIZE	AVERAGE HYDRAULIC DISCHARGE L/min	AVERAGE HYDRAULIC DISCHARGE Cbm/hour
EUROBRASS 143	1/2"	20 - 50	1,2 - 3
EUROBRASS 143	3/4"	50 - 75	3 - 4,5
EUROBRASS 143	1"	75 - 95	4,5 - 6
EUROBRASS 143	1" 1/4	95 - 130	6 - 8
EUROBRASS 143	1" 1/2	110 - 140	7 - 8,5
EUROBRASS 143	2"	120 - 160	7,5 - 10

## INSTALLATION OF THE PRESSURE REDUCING VALVE

The pressure reducers EUROBRASS 143 don't get the effects – for their functioning – of the gravity force; therefore they can be installed in the plant in any position:

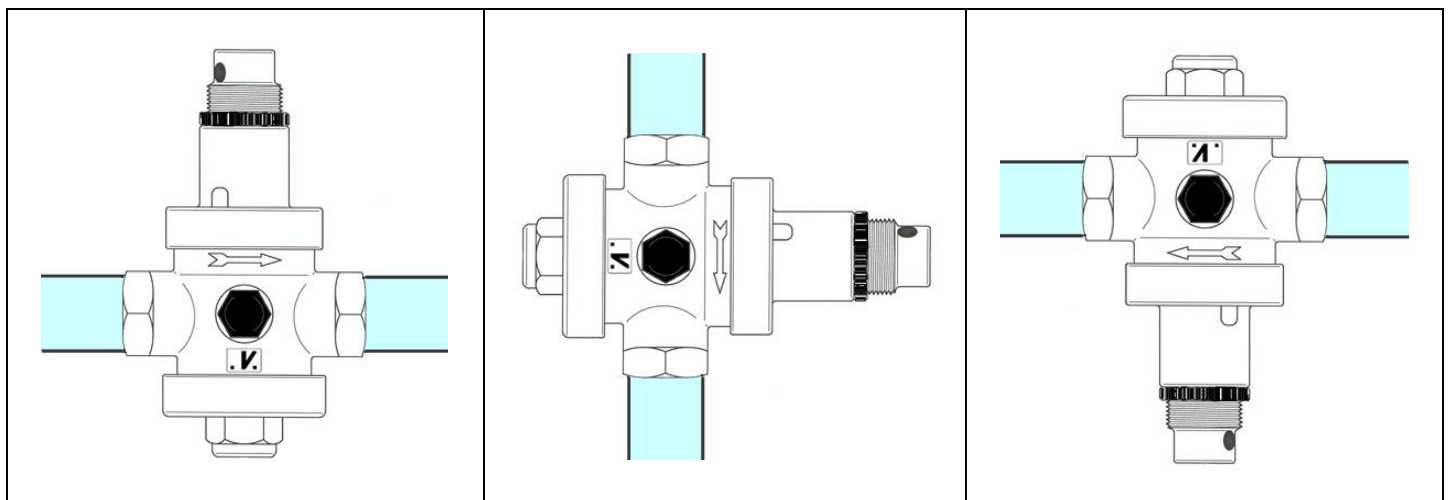

Pressure reducing valves can be damaged by dirty water; therefore we advise to install a self-cleaning filter upstream before the pressure reducer, in order to protect the valve and any other mechanism (thermostatic mixers, taps, etc.).

When there is a device which produce or store hot water or pipes are exposed to sudden changes in temperature, an increase of outlet pressure may occur; this event is due to the raise in pressure that follows the temperature rising: an expansion vessel between downstream the pressure reducing valve will avoid this problem.

We recommend moreover to install a Stopshock valve to prevent water hammer which would damage the inner parts of the pressure reducer and other devices in the waterworks.

Recommended installation of the pressure reducing valve:

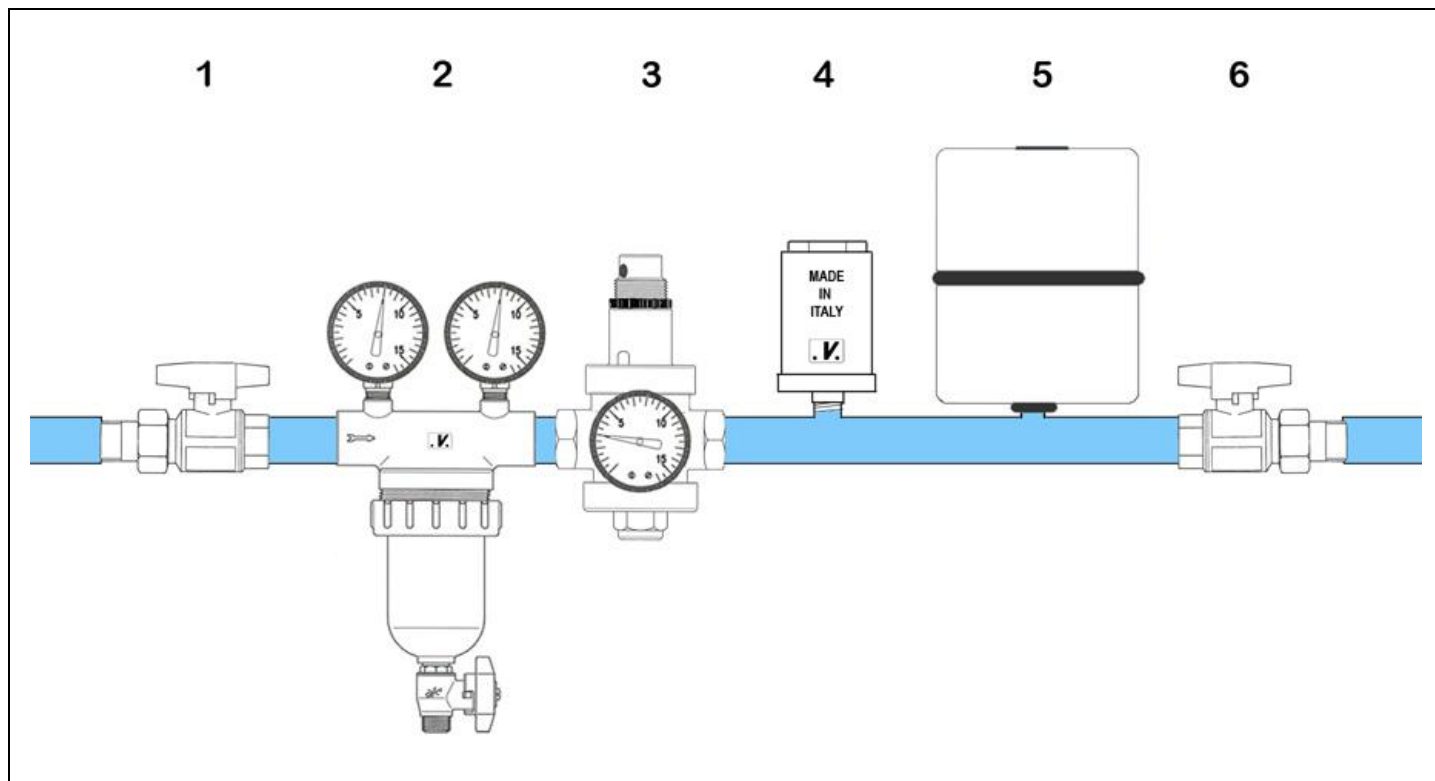

1 - BALL VALVE

2 - NEPTUN SELF-CLEANING FILTER

3 - EUROBRASS PRESSURE REDUCER

4 - STOPSHOCK VALVE

5 - EXPANSION VESSEL

6 - BALL VALVE

## HOW TO ADJUST THE PRESSURE

All Malgorani pressure reducers are tested before being packaged; during the proof they are pre-set at the outlet pressure of 3 bars; the model 142.

Installation or any change of outlet pressure must be performed by qualified personnel; In order to modify the outlet pressure, once removed the seal, you should only loosen the fixing ring and turn the spring holder as indicated in the pictures sequence. By turning clockwise the pressure increases, while counter-clockwise the pressure decreases.

A right setting has to be done while the plant outlet is closed.

